

Click object to rotate

Extend

Quattro Long Neck 40mm LNB
IDLR-QUTL40-EXTND-OPP
Item: 3404



Specifically designed for the European DTH markets, this LNB provides optimized reception capabilities and is designed to address the need to support multiple LNBs installations (on a single dish antenna) allowing for two 40mm brackets to be placed on its prolonged neck. This LNB enables the reception of signal from one satellite and its distribution to up-to 4 single tuner Set-top boxes (or 2 in the case of a twin-tuner STB), is ready for High-Definition transmissions and provides excellent Noise Figure performance. Manufactured to the highest industry quality standards and designed to meet strict specifications, this LNB is an ideal solution for the satellite broadcast reception across Europe.

Main Features:

- Long neck for multi satellite reception installations
- Low Phase Noise, DVB-S2 (HDTV) compliant
- Low Noise Figure
- Low power consumption
- High Cross-Pole performance
- High Frequency stability

Technical data

Low Band Input Frequency Range	10.7~11.7 GHz
Low Band Output Frequency Range	950~1950 MHz
LO Frequency	9.75 GHz
High Band Input Frequency Range	11.7~12.75 GHz
High Band Output Frequency Range	1100~2150 MHz
LO Frequency	10.6 GHz
Noise Figure	0.3dB typ. (0.7dB max.)
LO Initial Accuracy	+/- 1.0 MHz max.
LO Temperature Drift	+/- 3.0 MHz max.
LO Phase Noise @ 10K Hz	-80 dBc/Hz max.
Conversion Gain	55 dB min.
Gain Ripple	+/- 0.75 dB/27MHz
Gain Variation	+/- 4 dB
Image Rejection	40 dB min.
1 dB Compression Point (O/P)	0.0 dBm min.
Cross talk	20dB min.
Control Signals Ca [V]	11.0~14.0 V
Control Signals Cb [H]	16.0~20.0 V
Control Signals Cc [Band switching]	22KHz +/- 4KHz 0.4V – 0.8V pp
Output VSWR	2.5 : 1
Radiated Interference	-50 dBm max.
DC Power	200mA max. @ 11 – 20V
Working Temperature	-30~+60 °C
Output Impedance (connect to STB)	75Ω
Output connector	F-type (female)
Weight	243 g

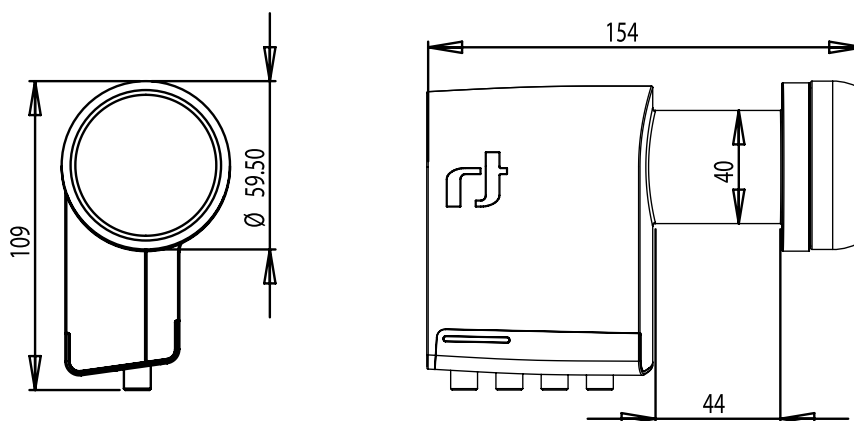

For purpose of brevity, some product descriptions in this sheet remain at platform level and may not be referred to as detailed datasheets of the products. Inverto Digital Labs reserves the right to amend, omit or add products, product-lines, and / or features without notice.

For further details contact: sales@inverto.tv

FTA Communication Technologies S.a.r.l Tel. +352 264 367 1 Fax. +352 264 313 68



www.inverto.tv